

WISENET

NETWORK INTERCOM

User Manual

TID-600R

CE

Network Intercom

User Manual

Copyright

©2021 Hanwha Techwin Co., Ltd. All rights reserved.

Trademark

Each of trademarks herein is registered. The name of this product and other trademarks mentioned in this manual are the registered trademark of their respective company.

Restriction

Copyright of this document is reserved. Under no circumstances, this document shall be reproduced, distributed or changed, partially or wholly, without formal authorization.

Disclaimer

Hanwha Techwin makes the best to verify the integrity and correctness of the contents in this document, but no formal guarantee shall be provided. Use of this document and the subsequent results shall be entirely on the user's own responsibility. Hanwha Techwin reserves the right to change the contents of this document without prior notice.

※ Design and specifications are subject to change without prior notice.

※ The initial administrator ID is "admin" and the password should be set when logging in for the first time.

Please change your password every three months to safely protect personal information and to prevent the damage of the information theft.

Please, take note that it's a user's responsibility for the security and any other problems caused by mismanaging a password.

IMPORTANT SAFETY INSTRUCTIONS

1. Read these instructions.
2. Keep these instructions.
3. Heed all warnings.
4. Follow all instructions.
5. Do not use this apparatus near water.
6. Clean the contaminated area on the product surface with a soft, dry cloth or a damp cloth. (Do not use a detergent or cosmetic products that contain alcohol, solvents or surfactants or oil constituents as they may deform or cause damage to the product.)
7. Do not block any ventilation openings, Install in accordance with the manufacturer's instructions.
8. Do not install near any heat sources such as radiators, heat registers, stoves, or other apparatus (including amplifiers) that produce heat.
9. Do not defeat the safety purpose of the polarized or grounding-type plug. A polarized plug has two blades with one wider than the other. A grounding type plug has two blades and a third grounding prong. The wide blade or the third prong are provided for your safety. If the provided plug does not fit into your outlet, consult an electrician for replacement of the obsolete outlet.
10. Protect the power cord from being walked on or pinched particularly at plugs, convenience receptacles, and the point where they exit from the apparatus.
11. Only use attachments/ accessories specified by the manufacturer.
12. Use only with the cart, stand, tripod, bracket, or table specified by the manufacturer, or sold with the apparatus. When a cart is used, use caution when moving the cart/ apparatus combination to avoid injury from tip-over.
13. Unplug this apparatus during lighting storms or when unused for long periods of time.
14. Refer all servicing to qualified service personnel. Servicing is required when the apparatus has been damaged in any way, such as power-supply cord or plug is damaged, liquid has been spilled or objects have fallen into the apparatus, the apparatus has been exposed to rain or moisture, does not operate normally, or has been dropped.
15. This product is intended to be supplied by a Listed Power Supply Unit marked "Class 2" or "LPS" or "PS2" and rated from 12 Vdc, 1.47A / PoE, 0.27A.
16. This product is intended to be supplied by isolation power.
17. If you use excessive force when installing the product, the intercom may be damaged and malfunction. If you forcibly install the intercom using non-compliant tools, the intercom may be damaged.
18. Do not install the product in a place where chemical substances or oil mist exists or may be generated. As edible oils such as soybean oil may damage or warp the product, do not install the product in the kitchen or near the kitchen table. This may cause damage to the product.
19. When installing the product, be careful not to allow the surface of the product to be stained with chemical substance. Some chemical solvents such as cleaner or adhesives may cause serious damage to the product's surface.
20. If you install/disassemble the product in a manner that has not been recommended, the production functions/ performance may not be guaranteed. Install the product by referring to "Installation & connection" in the user manual.
21. Installing or using the product in water can cause serious damage to the product.
22. Although a rapid change in temperature could cause frost inside the dome, there will be no problem with the video.



23. This device has been verified using STP cable. The use of appropriate GND grounding and STP cable is recommended to effectively protect your product and property from transient voltage, thunderstroke, communication interruption.

WARNING

TO REDUCE THE RISK OF FIRE OR ELECTRIC SHOCK, DO NOT EXPOSE THIS PRODUCT TO RAIN OR MOISTURE. DO NOT INSERT ANY METALLIC OBJECT THROUGH THE VENTILATION GRILLS OR OTHER OPENINGS ON THE EQUIPMENT.

Apparatus shall not be exposed to dripping or splashing and that no objects filled with liquids, such as vases, shall be placed on the apparatus.

To prevent injury, this apparatus must be securely attached to the Wall/ceiling in accordance with the installation instructions.

CAUTION

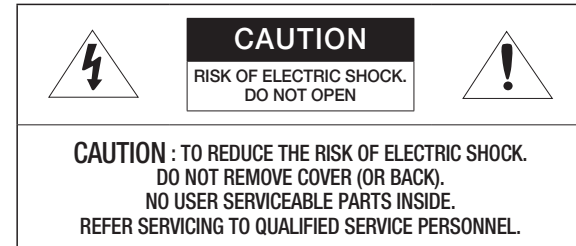

EXPLANATION OF GRAPHICAL SYMBOLS



The lightning flash with arrowhead symbol, within an equilateral triangle, is intended to alert the user to the presence of "dangerous voltage" within the product's enclosure that may be of sufficient magnitude to constitute a risk of electric shock to persons.



The exclamation point within an equilateral triangle is intended to alert the user to the presence of important operating and maintenance (servicing) instructions in the literature accompanying the product.

Class I construction

An apparatus with CLASS I construction shall be connected to a MAINS socket outlet with a protective earthing connection.

Battery

Batteries(battery pack or batteries installed) shall not be exposed to excessive heat such as sunshine, fire or the like.

The battery cannot be replaced.

Disconnection Device

Disconnect the main plug from the apparatus, if it's defected. And please call a repair man in your location.

When used outside of the U.S., it may be used HAR code with fittings of an approved agency is employed.

CAUTION

RISK OF EXPLOSION IF BATTERY IS REPLACED BY AN INCORRECT TYPE.
DISPOSE OF USED BATTERIES ACCORDING TO THE INSTRUCTIONS.

ATTENTION

IL Y A RISQUE D'EXPLOSION SI LA BATTERIE EST REMPLACÉE PAR UNE BATTERIE DE TYPE INCORRECT.

METTRE AU REBUT LES BATTERIES USAGÉES CONFORMÉMENT AUX INSTRUCTIONS.

CAUTION

These servicing instructions are for use by qualified service personnel only.

To reduce the risk of electric shock do not perform any servicing other than that contained in the operating instructions unless you are qualified to do so.

The Test Monitor Out port of the product is provided for easier installation, and is not recommended for monitoring purposes.

Please use the input power with just one intercom and other devices must not be connected.

Before connecting the Power Terminal Block, you need to unplug the power plug from the outlet first.

The ITE is to be connected only to PoE networks without routing to the outside plant.

The wired LAN hub providing power over the Ethernet (PoE) in accordance with IEEE 802.3.af shall be a UL Listed device with the output evaluated as a Limited Power Source as defined in UL60950-1 or PS2 as defined in UL62368-1.

Unit is intended for installation in a Network Environment 0 as defined in IEC TR 62102. As such, associated Ethernet wiring shall be limited to inside the building.

Please read the following recommended safety precautions carefully.

- Do not place this apparatus on an uneven surface.
- Do not install on a surface where it is exposed to direct sunlight, near heating equipment or heavy cold area.
- Do not place this apparatus near conductive material.
- Do not attempt to service this apparatus yourself.
- Do not place a glass of water on the product.
- Do not install near any magnetic sources.
- Do not block any ventilation openings.
- Do not place heavy items on the product.
- Please wear protective gloves when installing/removing the intercom.
The high temperature of the product surface may cause a burn.

User's Manual is a guidance book for how to use the products.

The meaning of the symbols are shown below.

- Reference : In case of providing information for helping of product's usages
- Notice : If there's any possibility to occur any damages for the goods and human caused by not following the instruction

※ Please read this manual for the safety before using of goods and keep it in the safe place.

We do not guarantee the quality of third-party products (e.g. lenses, accessories) that you separately purchase.

In particular installation environments, there might be interference in radio communications. When interference of electromagnetic waves occurs between the product and radio communication device, it is recommended to keep a certain distance between the two or change the direction of the receiving antenna.

WARNING

To Prevent damage which may caused by IR LED, don't stare at operating lamp.

For below models only.

TID-600R

Risk Group 1
WARNING IR emitted from this product. Do not stare at operating lamp.
Product tested against IEC 62471

CONTENTS

OVERVIEW 3	3	Important Safety Instructions
	6	Recommended PC Specifications
	6	Recommended Micro SD/SDHC/SDXC Memory Card Specifications
	6	Recommended Sip integration (VoIP, Peer-to-Peer, SIP/PBX)
	6	NAS recommended specs
	7	What's Included
	8	Optional Accessories for Installation
	9	At a Glance

INSTALLATION & CONNECTION 11	11	Installation
	16	Using touchless call
	16	Using the Status LED and Welcome functions
	17	How to use the SIP video call
	19	Connecting with other Device

NETWORK CONNECTION AND SETUP 27	27	Connecting the product Directly to Local Area Networking
	27	Connecting the product Directly to a DHCP Based DSL/Cable Modem
	28	Using Device Manager
	28	Automatically searching product
	28	Configuring IP address
	29	Manually registering product
	29	Automatically configuring IP
	30	Port Range Forward (Port Mapping) Setup
	31	Connecting to the product from a Shared Local PC
	31	Connecting to the product from a Remote PC via the Internet

WEB VIEWER 32	32	Connecting to the product
	33	Password setting
	33	Login
	33	Intercom Web Viewer Setup

APPENDIX 34	34	Troubleshooting
-----------------------	----	-----------------

RECOMMENDED PC SPECIFICATIONS

- CPU : Intel(R) Core(TM) i7 3.4 GHz or higher
 - RAM : 8G or higher
 - Recommended browser: Chrome
 - Supported browsers: Chrome, Safari, Firefox, MS Edge(chromium based)
 - Supported OS : Windows, Mac, Linux, Android, iOS, Chrome
 - Verification environment
 - Windows 10: Google Chrome version 80 or later, Firefox version 72 or later, MS Edge version 83 or later
 - Mac 10.13/14: Safari version 11.0.1 or later
- ※ The video play performance of the web viewer depends on the performance of the user's CPU and GPU.

RECOMMENDED MICRO SD/SDHC/SDXC MEMORY CARD SPECIFICATIONS

- Recommended capacity : 16 GB to 256 GB (MLC type required)
- Recommended Manufacturers : SanDisk, Transcend
- Product Type : High endurance
- The compatibility varies depending on the card manufacturers and types.

RECOMMENDED SIP INTEGRATION (VoIP, PEER-TO-PEER, SIP/PBX)





- Tested with Cisco, Grandstream, Yealink VoIP phones and Asterisk PBX software



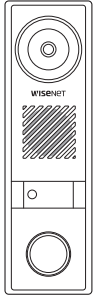
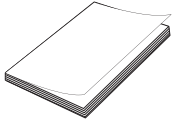
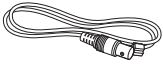
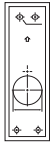

NAS RECOMMENDED SPECS

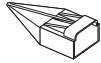
- Recommended capacity : 200GB or higher is recommended.
- For this intercom, you are recommended to use a NAS with the following manufacturer's specs.
Recommended products : QNAP NAS, Synology NAS

WHAT'S INCLUDED

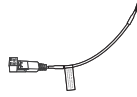

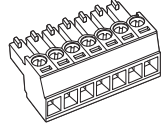
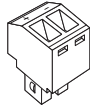
Please check if your intercom and accessories are all included in the product package.
(As for each sales country, accessories are not the same.)

Appearance	Item Name	Quantity	Description
	Intercom	1	
	Quick Guide (Optional)	1	
	Cable for the testing monitor	1	Used to test the intercom connection to a portable display device
	Template	1	Product installation guide
	Torx L wrench	1	To remove/fix the Mount plate
	Cap Installer	1	Used to connect the RJ45 network cable
	Alarm Cable	1	Used to connect to alarm terminal block

Appearance	Item Name	Quantity	Description
	Power cable	1	Used to connect to power terminal block
	Cable bushing	1	Extra cable bushing for network cable installation.
		1	Extra cable bushing to connect to power and alarm terminal blocks
	Alarm Terminal Block	1	Plugged in the Alarm cable port
	Power Terminal Block	1	Plugged in the Power Port (DC 12 V)
	Touchless call guidance sticker	1	Adhere to the intercom when using the Touchless call function

OPTIONAL ACCESSORIES FOR INSTALLATION

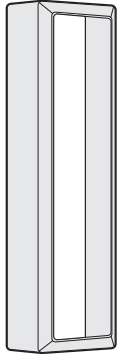
You can purchase appropriate optional accessories available.

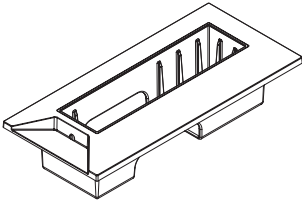
Product type	Skin Cover	Tilt mount	Flush mount
Model Name	SBC-165W (White)	SBS-165TM	SHS-165F
			

AT A GLANCE

Appearance

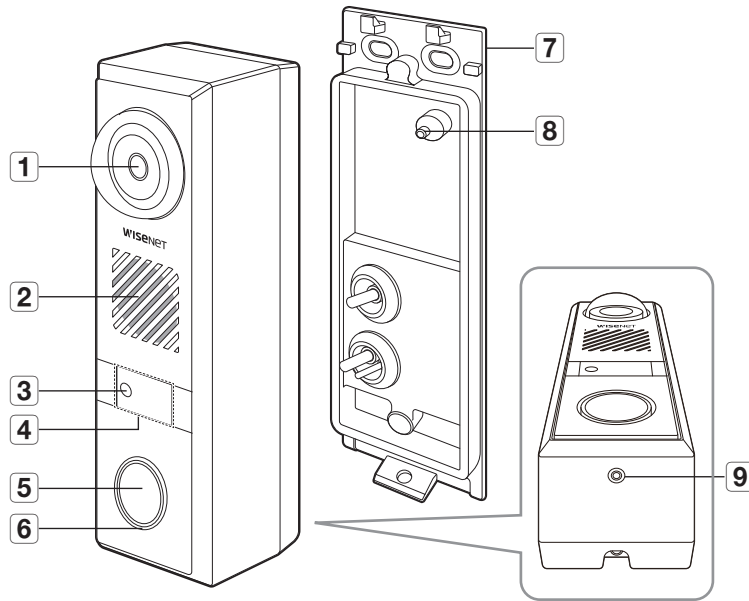

Item	Description
1 Lens	Camera Lens for the intercom.
2 Speakers	Outputs audio transmitted from the connected device.
3 IR LED/ Illumination Sensor	These infrared LED's are controlled by the illumination sensor. / Detects incoming light to control the IR LED.

Item	Description
4 Touchless call sensor	If your hand is within the distance of 15 cm (6 inch) from the sensor for at least 1 second, it will be called even if you do not press the Call button. Refer to "Using touchless call" on page 16.
5 Call Button	The call button for calling.
6 LED status indicator	LED indicator shows operational status with colors. *
7 Mount plate	The mount plate for installation.
8 Tampering switch depressor	Using the tampering switch, you can detect when the product is somehow separated.
9 Built-in Mic	Built-in mic picks up sound.

* LED status

LED indicator shows operational status with colors.
Refer to table below for detailed meaning of the LED indicator.

Color	Type	Status
Blue	Steady / On when sensor detected	Idle
Blue	Blink	Call button push & call waiting
Blue	Slow blink	Calling
Green	Steady	Relay activation
Red	Steady	Booting up
Red	Blink	Communication error
White	Steady	Firmware update

Inside

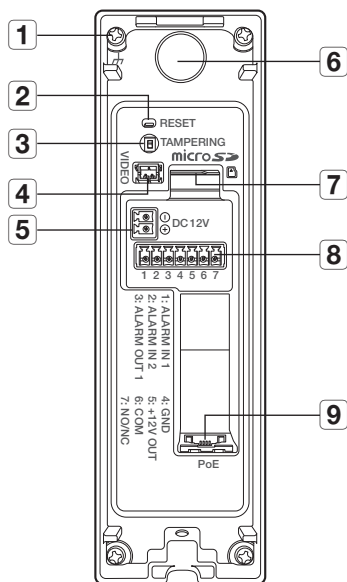

Item	Description
6 Gore sheet	Waterproof/dampproof sheet for the holes where the sheet is attached. I Never remove this since it is a waterproof sheet.
7 Micro SD card slot	Compartment for the Micro SD card.
8 Alarm cable port	Used to connect the alarm input/output devices including electric door locks.
9 Network Port	Used to connect the PoE or Ethernet cable for network connection.

Item	Description
1 GND	Used to discharge the lightning current safely outside in order to protect the intercom.
2 Reset Button	The button restores all intercom settings to the factory default. Press and hold for about 5 seconds to reboot the system. I If you reset the intercom, the network settings will be adjusted so that DHCP can be enabled. If there is no DHCP server in the network, you must run the Device Manager program to change the basic network settings such as IP address, Subnet mask, Gateway, etc., before you can connect to the network.
3 Tampering Switch	Sensor module that triggers alarm when the device is physically damaged or stolen. To use this function, <Tampering switch> needs to be enabled in the web viewer settings menu.
4 Test monitor out port	Output port for test monitoring the video output. Use the test monitor cable to connect to a mobile display and check the test video.
5 Power port (DC 12V)	Port for power terminal block.

INSTALLATION

Precautions before installation

Ensure you read out the following instructions before installing the intercom:

- Select an installation site that can hold at least 5 times the intercom's weight.
- Stuck-in or peeled-off cables can cause damage to the product or a fire.
- For safety purposes, keep anyone else away from the installation site. And put aside personal belongings from the site, just in case.
- If the product is installed with excessive force, it may cause damage to the intercom due to malfunction. Forcing assembly using non-compliant tools may damage the product.

Disassembling

1. Using the provided Torx L wrench, turn the screws on the bottom of the product counterclockwise and release the mount plate.

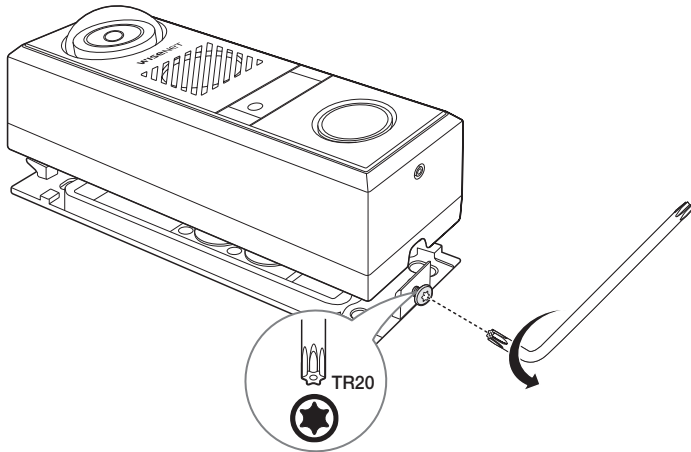

Inserting a Micro SD card

Slide the Micro SD card into the Micro SD card slot on the intercom in the direction of the arrow.

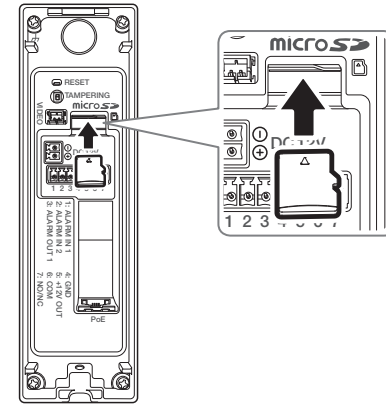

- ! Before installing the intercom, the Micro SD card should be inserted while the power source and the body are separated.
- Do not forcefully insert it in the reverse direction. It might damage your Micro SD card and your product.
- When it rains or the humidity is high, insertion or ejection of a Micro SD card is not recommended.
- Disassembly of the product cover should be finished within 5 minutes, or there will be the risk of internal dew condensation.

Removing a Micro SD card

Gently press down on the exposed end of the Micro SD card as shown in the diagram to eject the Micro SD card from the slot.

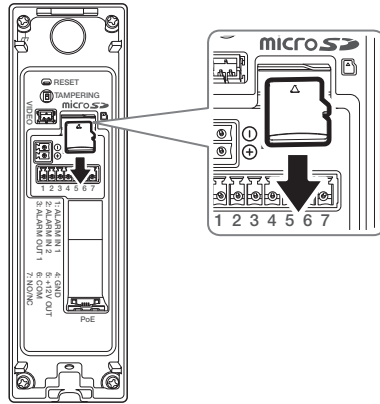

- ! Before removing the Micro SD card, in **<Setup (⚙️)>** **<Event>** **<Storage>**, set the device to **<Off>** and press the **[Apply]** button and turn the intercom off.
- If you turn off the intercom or remove the Micro SD card that contains data from the product, the data may be lost or damaged.

Installing the intercom on the wall

1. Attach the template in the location you want in consideration of the recommended height shown below, and then drill wiring holes and installation screw holes.

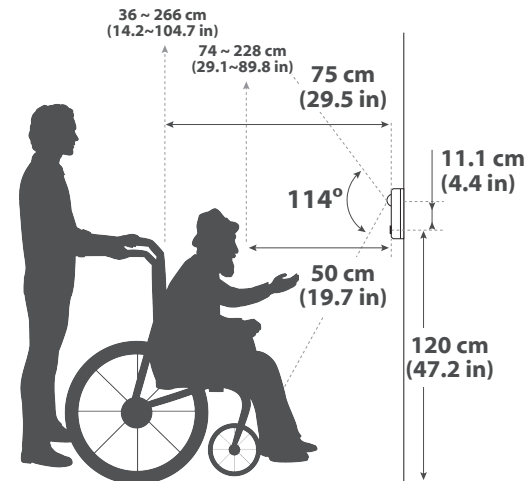
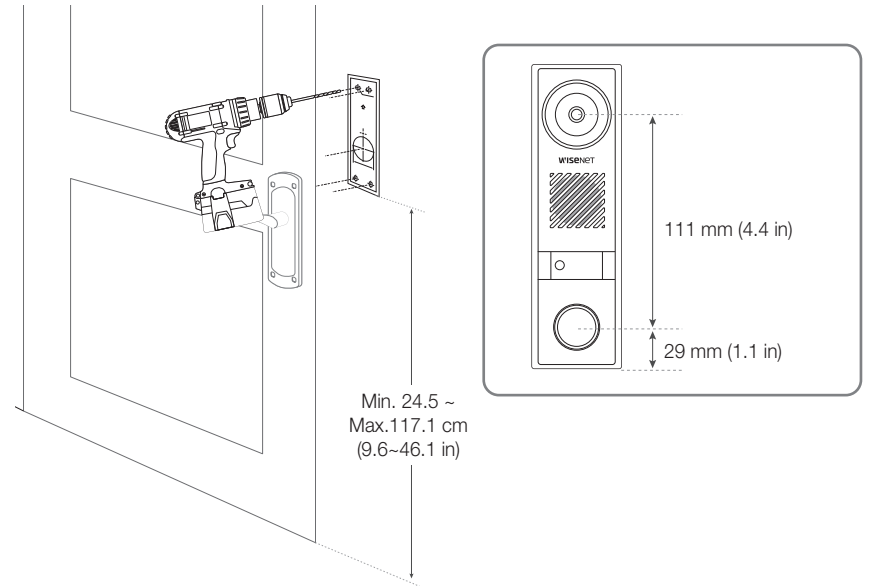

2. Pass the audio/alarm/power cable and the network cable through the hole.

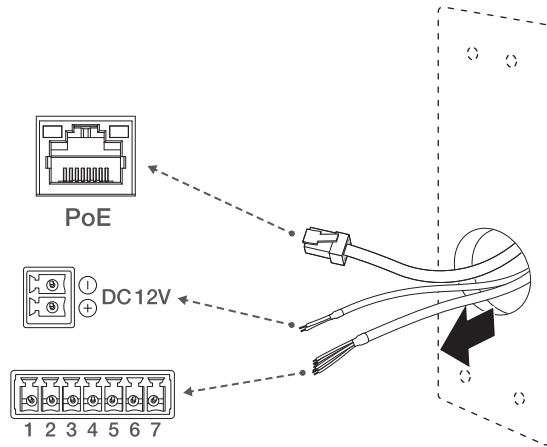

3. Remove the cable bushing from the mount plate.

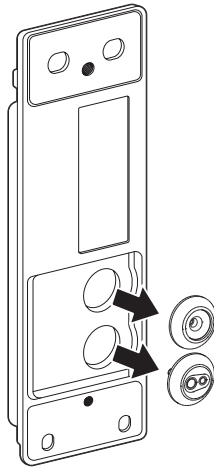

[Installing the network cable]

- ☑ The diameter of the network cable is $\varnothing 5\sim 6.5$.
- 4. Pull off the extruded parts of the cable bushing to be used.
- 5. Use the cap installer to route the network cable through the cable bushing.

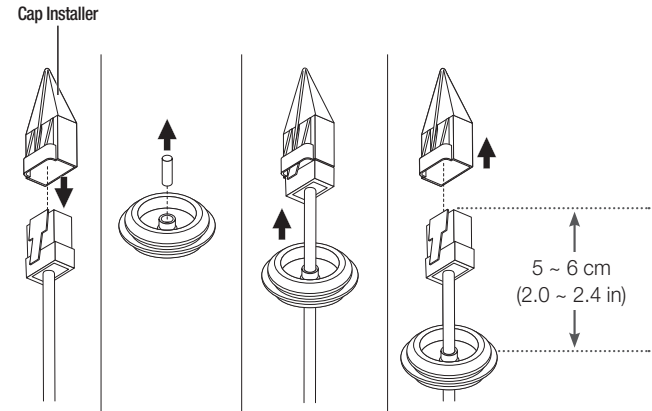

[Installing power and alarm I/O cables]

- 6. Pull off the extruded parts of the cable bushing to be used.
- 7. Pass the provided alarm cable through the big hole of the cable bushing.
- 8. (When using DC 12 V power) Pass the provided power cable through the small hole of the cable bushing.

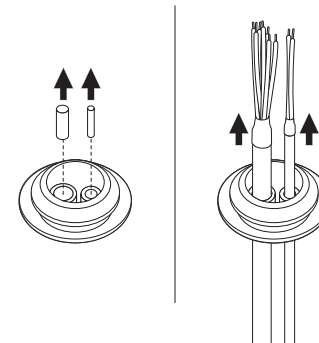

- ! When power input is connected with PoE only, do not tear off the extruded part of the small hole in the cable bushing.
- The DC power and alarm cables provided together must be used.

installation & connection

9. Insert the bushing of the alarm cable in the bottom hole of the mount plate, and the bushing of the network cable in the top hole.

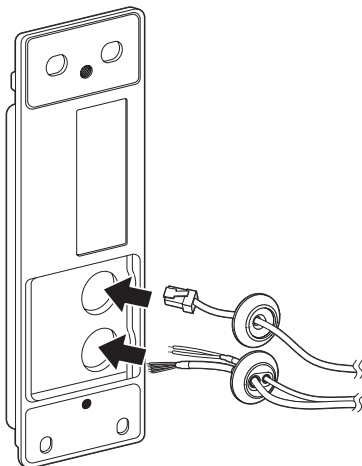

10. Connect the alarm terminal block to the alarm cable, and power terminal block to the power cable.

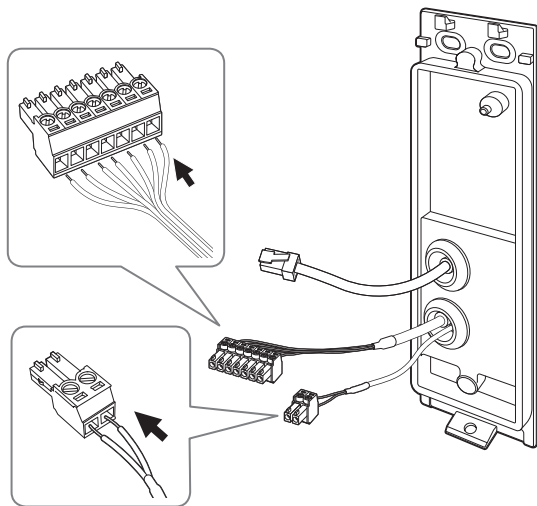

11. Fix the mount plate using appropriate screws. (M4.5xL50).

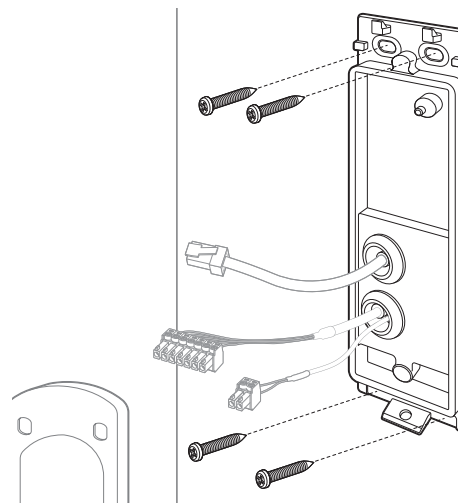

12. Connect alarm and power terminal blocks to the corresponding ports.

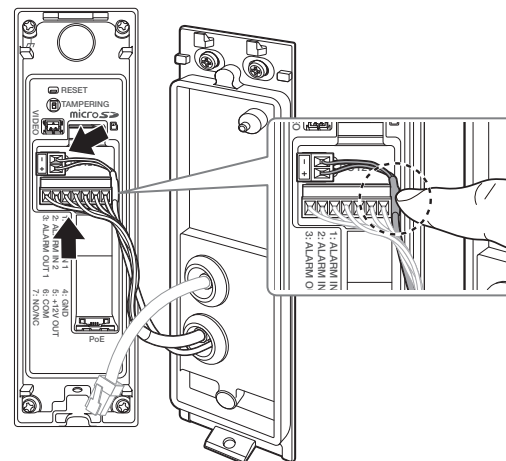

- ! ■ Route the DC power cable to pass by the alarm I/O port as shown in the figure.

13. Connect the network cable to the network port.

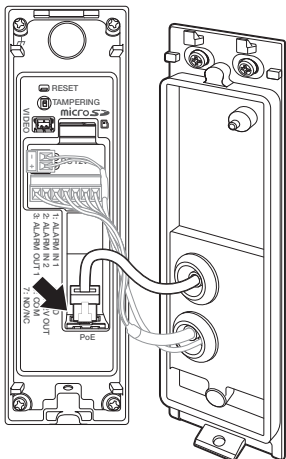

15. Tighten the screw while pushing the bottom part of the camera body.

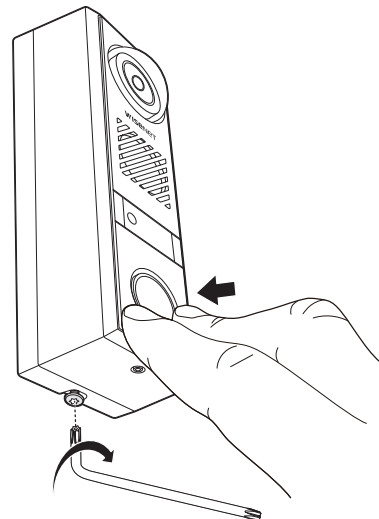

14. Join the camera body to the mount plate.

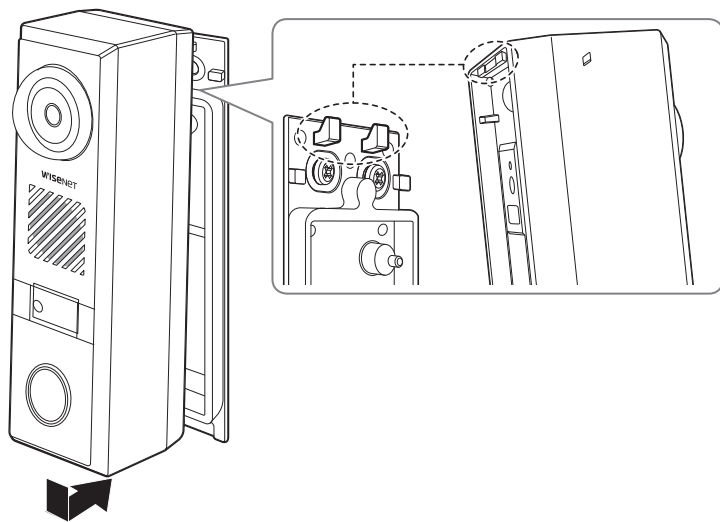

USING TOUCHLESS CALL

Attaching a touchless call guide sticker

In case of making a touchless call, the guide sticker provided as a component can be attached to the Intercom, as shown in the picture below. When attaching the guide sticker, pay attention not to stain the front sensor area with fingerprints.

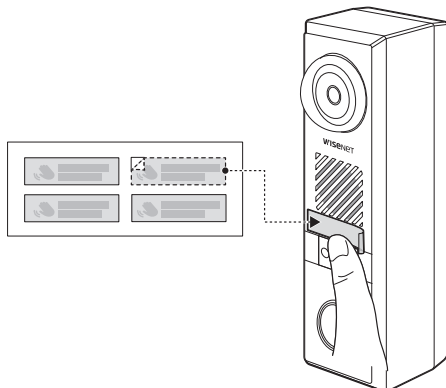

Setting up touchless call

Go to <Setup (⚙️)> - <Intercom> - <Call Setup> - <Touchless call> and check the <Enable> box.

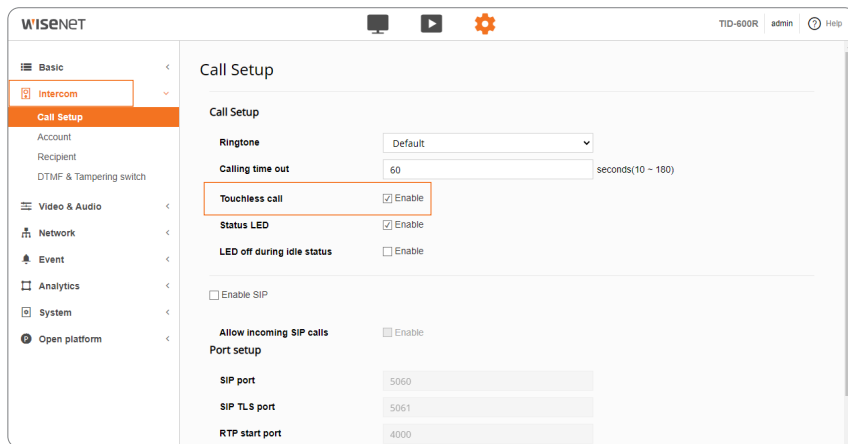

How to use touchless call

When your hand is within 2~15cm from the front sensor, it is possible to make a call without pressing the Call button.

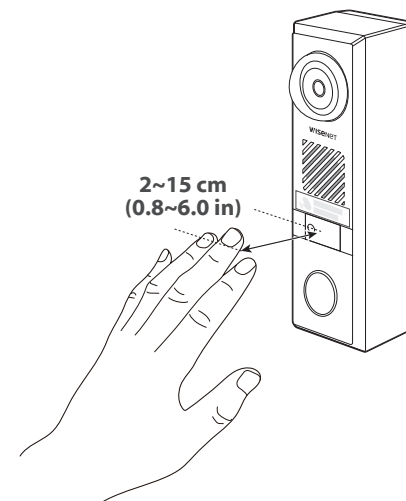

- ! Rather than waving your hand, not moving it for about one second has a higher detection rate.
- It may malfunction when the front window is stained with frost or foreign substances. To use touchless call, keep the touchless call sensor and its area clean after installing the intercom.

USING THE STATUS LED AND WELCOME FUNCTIONS

Setup the Status LED

To turn on the LED Status Indicator on the intercom's front all the time, check <Enable> of <Status LED> in <Setup (⚙️)> - <Intercom> - <Call Setup>, and uncheck <LED off during idle status>.

Setup the Welcome function

To turn off the LED Status Indicator on most days and turn it on only when a visitor approaches, check both <Status LED> and <LED off during idle status> in <Setup (⚙️)> - <Intercom> - <Call Setup>.

When a visitor approaches within 80 cm from the Intercom's front, the Status LED Indicator lights up.



HOW TO USE THE SIP VIDEO CALL

To use the SIP video call function with the intercom, the following four must be set up.

If any of them are not set up, you cannot use the SIP video call function. Once all configurations are complete, test the video call to ensure that the system works properly.

Required setup

- VoIP video profile registration
- SIP activation
- Account registration
- Recipient registration

Registering a VoIP profile

1. Enter the IP address of the intercom in the address bar of the browser.
2. Go to <Setup ()> - <Basic> - <Video Profile> and click the [Add] button to add a VoIP video profile.
3. Check <VoIP profile> in <Profile type>.

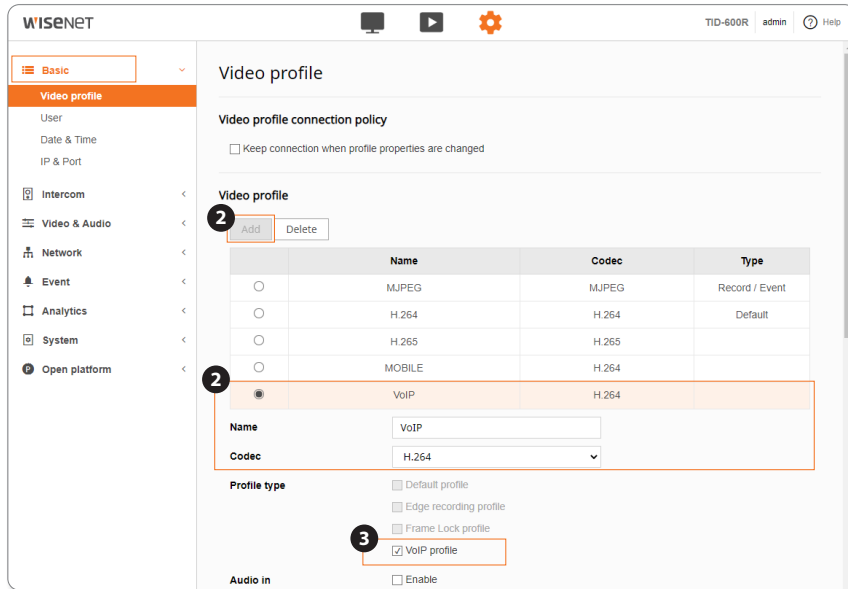

Video profile

Video profile connection policy

Keep connection when profile properties are changed

Video profile

Name	Codec	Type
MJPEG	MJPEG	Record / Event
H.264	H.264	Default
H.265	H.265	
MOBILE	H.264	
VoIP	H.264	

Profile type

Default profile

Edge recording profile

Frame Lock profile

VoIP profile

Audio in

Enable

4. Set the three items in <Profile properties> according to the specifications of the client device to connect.

 If the set value is not supported by the client device (e.g. video phone), the video feed from the intercom might not be received. Therefore, you need to check the specifications of the relevant device before setup.

5. Click the [Apply] button at the bottom of the screen to complete the setup.

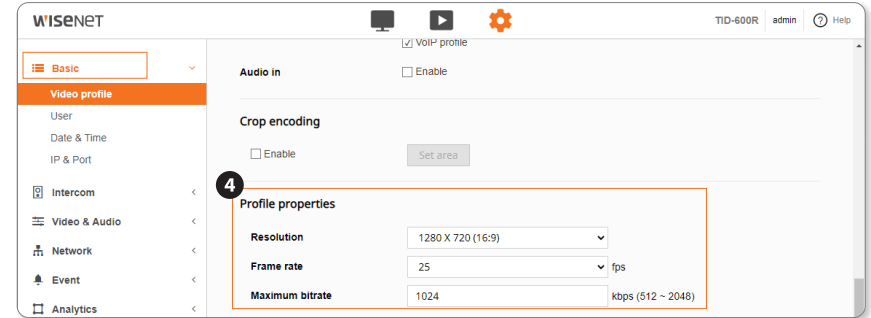

Profile properties

Resolution: 1280 X 720 (16:9)

Frame rate: 25 fps

Maximum bitrate: 1024 kbps (512 ~ 2048)

Activating the SIP function

1. Go to <Setup ()> - <Intercom> - <Call setup> and check the <Enable SIP> box..
2. Click the [Apply] button at the bottom of the screen to complete the setup.

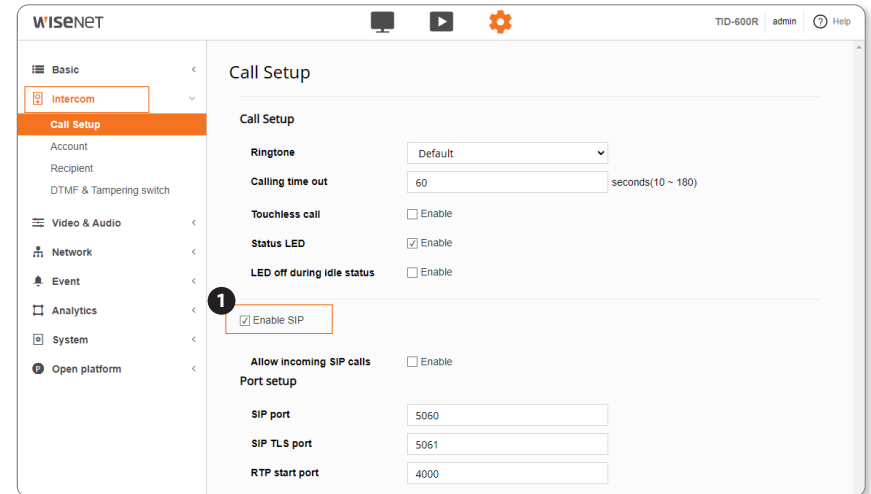

Call Setup

Ringtone: Default

Calling time out: 60 seconds(10 ~ 180)

Touchless call: Enable

Status LED: Enable

LED off during idle status: Enable

Enable SIP

Allow incoming SIP calls: Enable



Port setup

SIP port: 5060

SIP TLS port: 5061

RTP start port: 4000

Registering an account

- Go to <Setup ()> - <Intercom> - <Account> - <Account list> and click the [Add] button to register a new account.
 - Check the <Use> box of the registered account in the list.
 - Click the [Apply] button at the bottom of the screen to complete the setup.
 - Click the [Refresh] button in the list to check if <Status> changes to <Available>.
-  Clicking the [Refresh] button may take several seconds to take effect depending on the server network environment.
- <Unavailable> is displayed for <Status> if incorrect ID, PW or Server IP is entered.
 - For more detailed description of these terms, see <?> [Help] of the web viewer.

Add account

Account information

Name

User ID

Authentication ID

Password

Domain name

Advanced setup ▾ Entering the SIP server IP

Registering a recipient

- Go to <Setup ()> - <Intercom> - <Recipient> - <Recipient list> and click the [Add] button to register a new recipient.
- Select from the registered recipients in <Call Request>.
- Click the [Apply] button at the bottom of the screen to complete the setup.

Add recipient

Name

SIP address

Type

Group

Group 1

Group 2

Group 3

Group 4

Group 5

Check and enter the SIP server IP.

WISNET

TID-600R admin Help

Basic

Intercom

Call Setup

Account

Recipient

DTMF & Tampering switch

Video & Audio

Network

Event

Analytics

System

Open platform

Account

Account list

1 Add
3 Refresh

Select	Use	Name	User ID	Domain name	Transport mode	Status
<input type="radio"/>	<input type="checkbox"/>	peer-to-peer	peer-to-peer	192.168.1.11	UDP	Available
<input type="radio"/>	<input checked="" type="checkbox"/>	Intercom	example_id	192.168.1.254	UDP	3 Available

Video profile

Name VoIP

Codec H264

Resolution 1280x720

Frame rate 25

Crop encoding false

3

-  If you do not see the VoIP profile information in the <Video Profile> field, see 'Registering a VoIP video profile' on page 17.

WISNET

TID-600R admin Help

Basic

Intercom

Call Setup

Account

Recipient

DTMF & Tampering switch

Video & Audio

Network

Event

Analytics

System

Open platform

Recipient

Call request

Single Group (Parallel forking)

Recipient list

Group All 1 2 3 4 5

1 Add
1 Delete
1 Delete all

Select	Name ▲	SIP address ▲	Type ▲	Group
<input type="checkbox"/>	phone	sip:phone@192.168.1.254	Registrar	<input checked="" type="checkbox"/> 1 <input type="checkbox"/> 2 <input type="checkbox"/> 3 <input type="checkbox"/> 4 <input type="checkbox"/> 5

3

Testing a video call

Once all four of them are set up, click the Call button on the intercom to see if the video call can be successfully made.

-  The intercom and the device to use for sending and receiving video call (VoIP phone) must be set up and connected to the server already.

CONNECTING WITH OTHER DEVICE

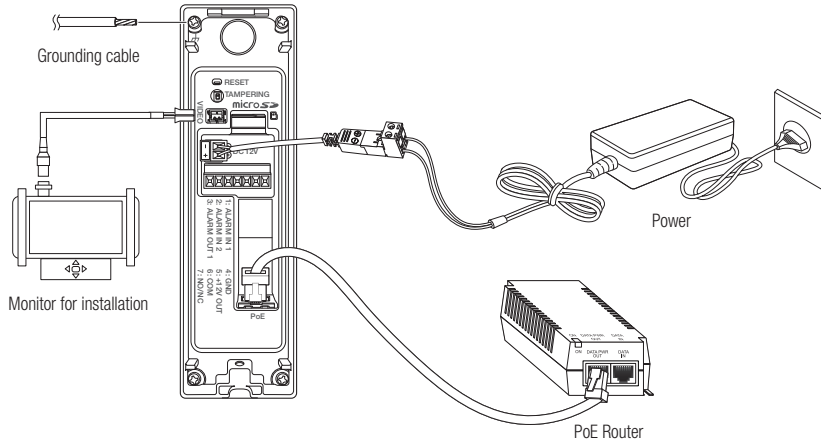

- ! The Test Monitor Out port of the product is provided for easier installation, and is not recommended for monitoring purposes.

Ethernet Connection

Connect the Ethernet cable to the local network or to the Internet.

Powering and networking

Connect the PoE device with the PoE of the intercom.

- !
 - Connect and use a PoE enabled router.
 - If you connect using an PoE enabled router, you don't need a separate power supply cable to power it on.
 - Use a PoE device that complies with the IEEE 802.3af standard.

Power Supply

Use the screwdriver to connect each line (+, -) of the power cable to the corresponding power port of the intercom.

- !
 - If both PoE and DC12V are applied simultaneously, the product will be supplied with power from PoE.
 - It is advisable to use only one power source from PoE and DC 12V.
 - Be careful not to reverse the polarity when you connect the power cable.
 - If you want to connect an external device, you must turn off the external device before proceeding.
 - To use it in connection with electric door strike, you need DC 12V power supply.

Power Cable Specification

In case of DC 12V Input:

Wire Type (AWG)	#20	#18	#16
Cable Length (Max.)	13 m	21 m	30 m

Network Cable Specification

Item	Contents	Remark
Connector	RJ45 (10/100BASE-T)	
Ethernet	10/100BASE-T	
Cable	Category 5e	
Max Distance	100 m	DC Resistance $\leq 0.125 \Omega/m$
PoE Support	IEEE 802.3af	

- ☑ Use an STP cable to increase the protection from thunderstroke damage.

Connecting electric door strike

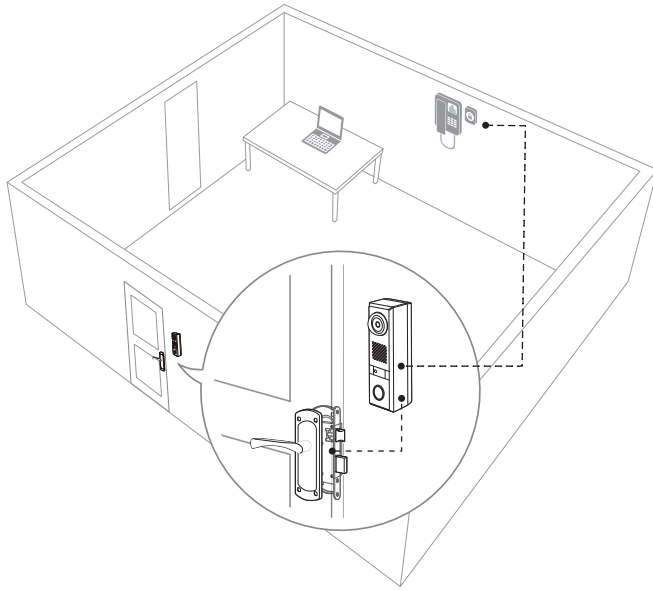

- !
 - To operate the electric door strike with intercom, connect DC 12V power. If only PoE power is supplied, the electric door strike won't operate.
 - The maximum power that can be supplied by Alarm out No.2 (NO/NC port) is DC 12V / 550mA.
 - If you are using no PoE but only DC 12V power, DC 12V / minimum 1.47A power or higher is needed. DC 12V / 2A or higher is recommended.
 - When simultaneously using both PoE and DC 12V, select the DC 12V power capacity that meets the specifications of the device connected to Alarm out No.2 (NO/NC port).
 - Refer to the specifications recommended by the electric door strike manufacturer for the length and depth of the cable connecting electric door strike and intercom.
 - If only PoE is connected to the intercom, only the intercom works and the door strike does not.
 - If PoE and DC12V power adapter are connected to the intercom: the intercom is powered by PoE, while the door strike is powered by the DC12V power adapter (DC12V, 550mA).
 - If 100Mbps Ethernet LAN cable and DC12V power adapter are connected to the intercom: both the intercom and door strike are powered by the DC12V power adapter (DC12V, 1.47A).

Electric door strike wiring diagram (controlled by web viewer or VoIP phone)

! ▪ The web viewer setting of the intercom may vary depending on the type of the door strike.

▪ Door Strike powered by TID-600R

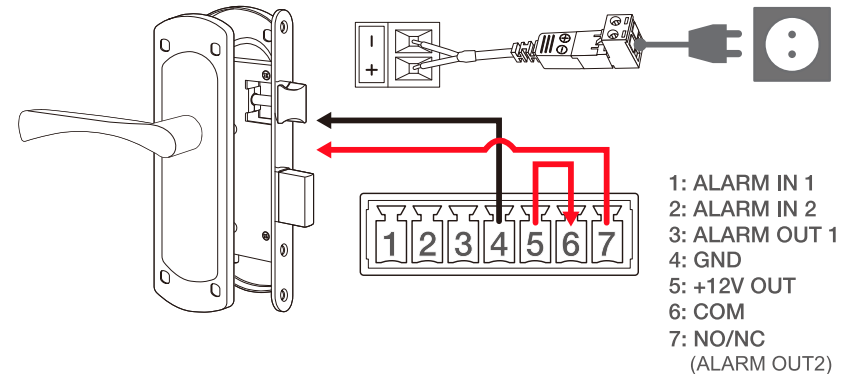
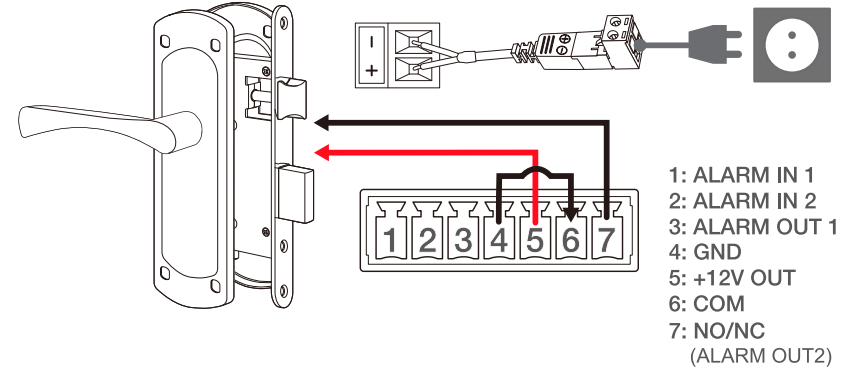

▪ Door Strike powered by Power Supply

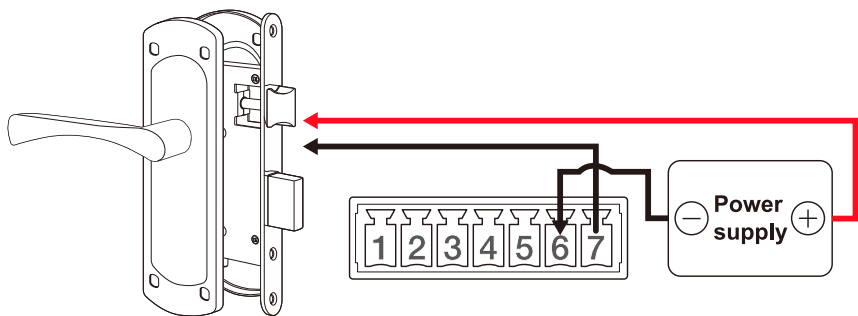

- 1: ALARM IN 1
- 2: ALARM IN 2
- 3: ALARM OUT 1
- 4: GND
- 5: +12V OUT
- 6: COM
- 7: NO/NC (ALARM OUT2)

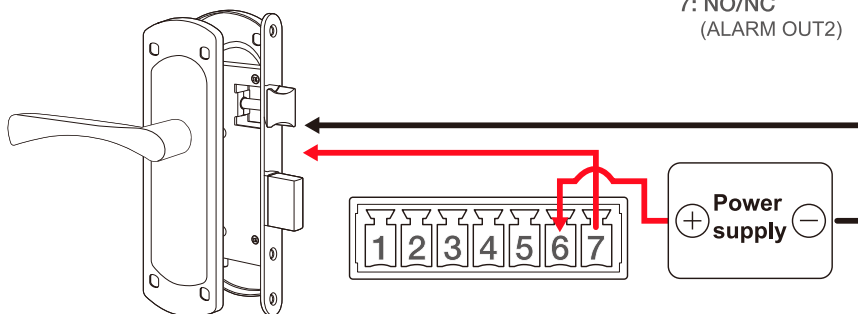

Setting up when using the Fail-Safe type door strike

1. Enter the IP address of the intercom in the address bar of the browser.
2. Go to <Setup (⚙️)> - <Event> - <Alarm output> - <Alarm output2(NO/NC port)> and select <N.C. (Normal Close)>.
3. To change the duration during which the door is open, select <Mode> - <Pulse> and set <Duration> to the desired value.
 - The door remains open for the specified duration, and then it closes.

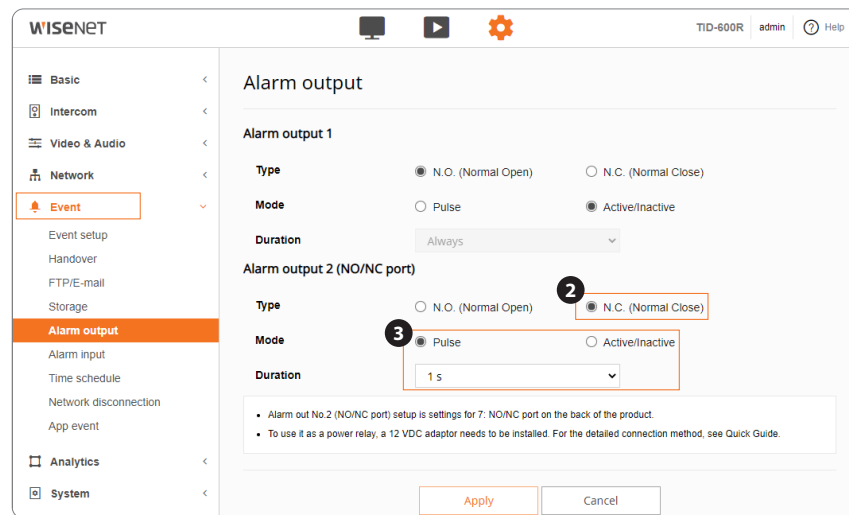

Setting up when using the Fail-Secure type door strike

1. Enter the IP address of the intercom in the address bar of the browser.
2. Go to <Setup (⚙️) - <Event> - <Alarm output> - <Alarm output2(NO/NC port)> and select <N.O. (Normal Open)>.
3. To change the duration during which the door is open, select <Mode> - <Pulse> and set <Duration> to the desired value.
 - The door remains open for the specified duration, and then it closes.

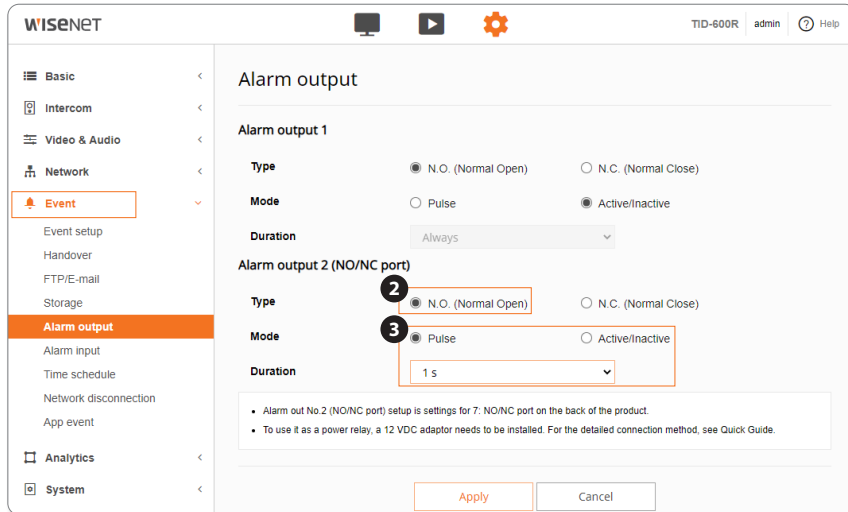

Opening door using web viewer

1. Set <Alarm output2(NO/NC port)> and <Duration> according to the door strike type.
2. Click the relay (🔌) button on the web viewer live screen.
 - The door remains open for the specified duration, and then it closes.

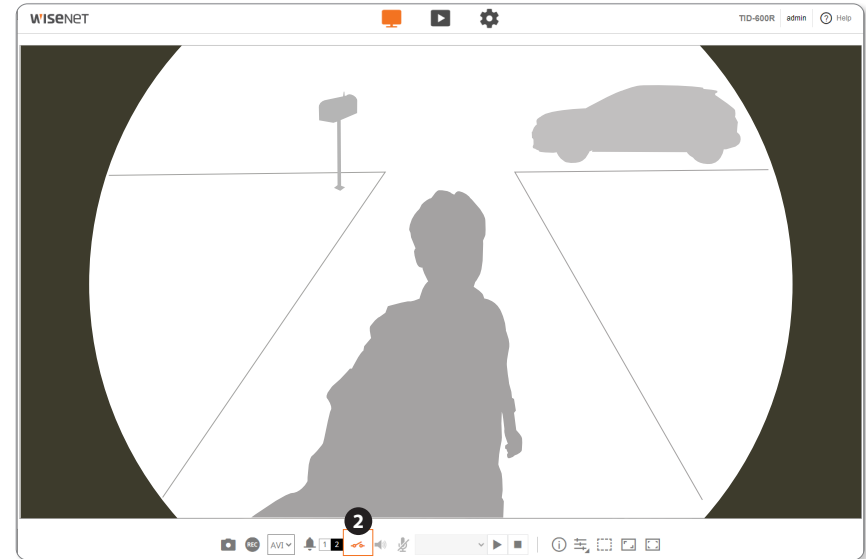

Opening door with DTMF code on the VoIP Phone

1. Go to <Setup (⚙️)> - <Intercom> - <DTMF & Tampering switch> and check the <Enable DTMF code reception> box.
2. In <Code>, register the code number to be entered in the VoIP phone.
3. Set the duration during which the door is open in <Alarm output 2 (NO/NC port)> under <Event action setting>.
 - Once you enter the code number registered in VoIP phone, the door remains open for the specified duration, and then it closes.

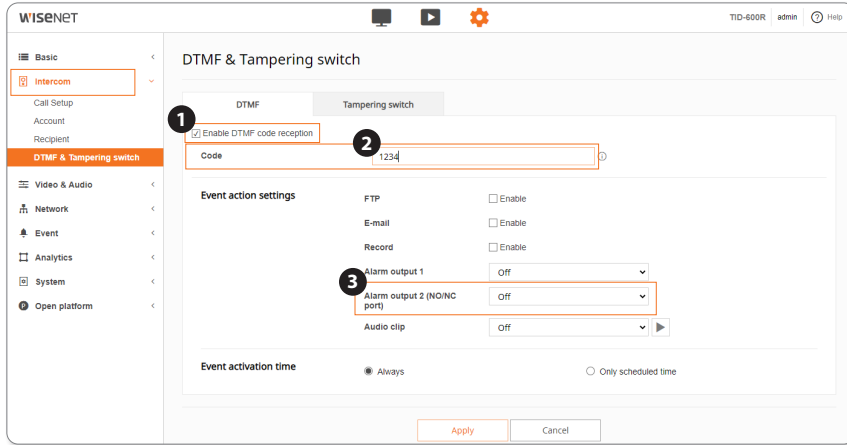

■ SIP Info(RFC2976) and RTP (RFC2833) methods are supported for receiving DTMF code.

Electric door strike wiring diagram (controlled with Door exit button)

! ■ The web viewer setting of the intercom may vary depending on the type of the door strike.

- Door Strike powered by TID-600R + Door exit Button

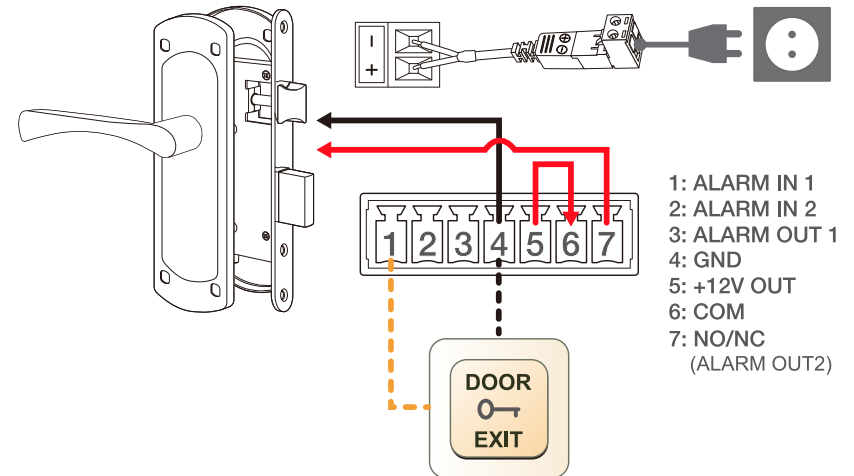
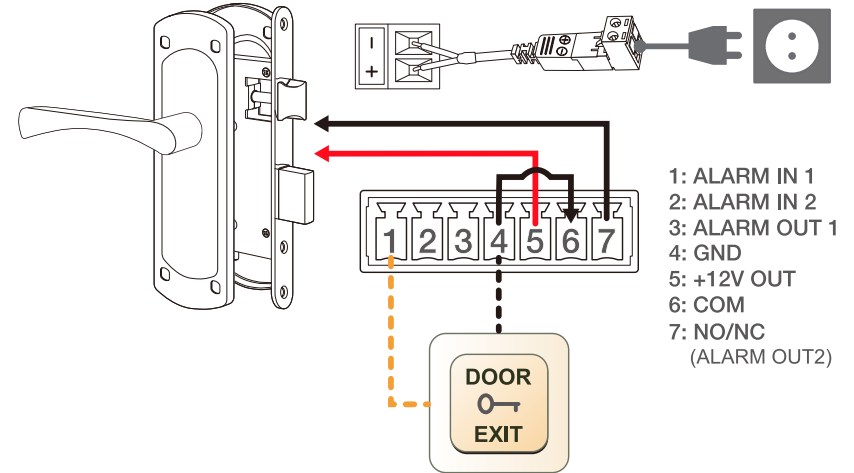

▪ Door Strike powered by Power Supply + Door exit Button

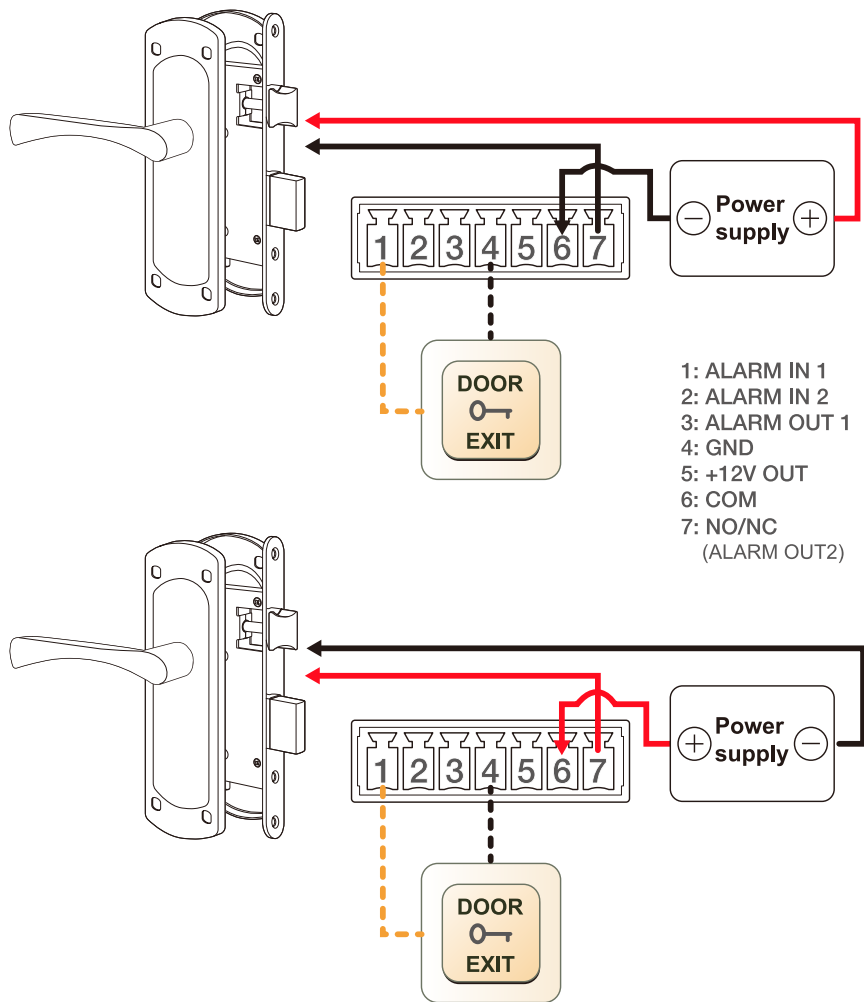

Opening door using Door exit button

- Go to <Setup (⚙️)> - <Event> - <Alarm input> - <Alarm input no.> and select the alarm channel depending on the Door exit button connection.
 - When connecting to alarm terminal block no. 1 and 4, select 1 for <Alarm input no.>.
 - When connecting to alarm terminal block no. 2 and 4, select 2 for <Alarm input no.>.
- Select <Enable> for <Input device setup>.
- Set the duration during which the door is open in <Alarm output 2 (NO/NC port)> under <Event action setting>.
 - Once Door exit button is pressed, the door remains open for the specified duration, and then it closes.

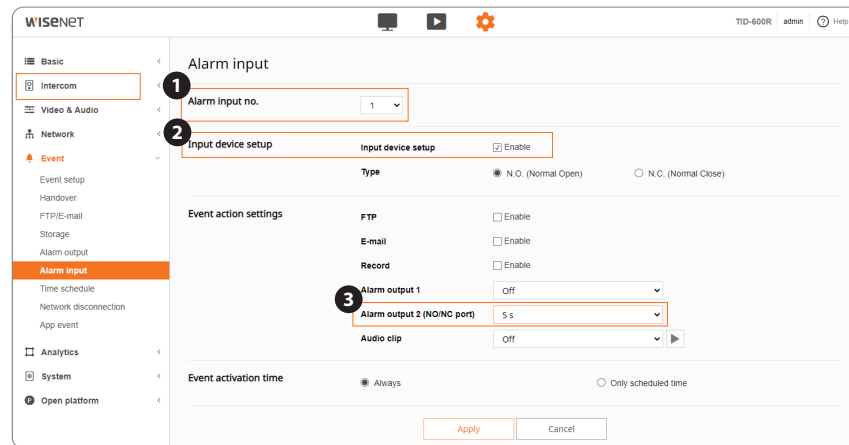

To connect the Alarm Out 1

If devices (e.g., flashing light and siren) that exceed the voltage and current specifications are connected by using the open collector method, it may cause malfunction.

Refer to the alarm out connection diagram below when connecting devices that exceed the voltage and current specifications.

Alarm Out 1 Wiring Diagram

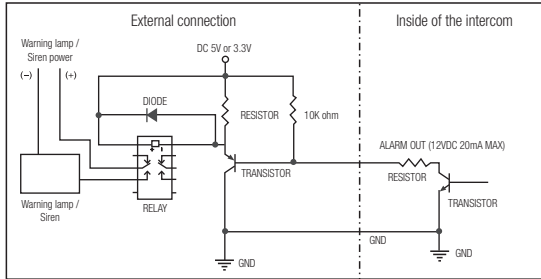

To connect the Alarm Out 2 (NO/NC)

Alarm Out 2 (NO/NC) Wiring Diagram

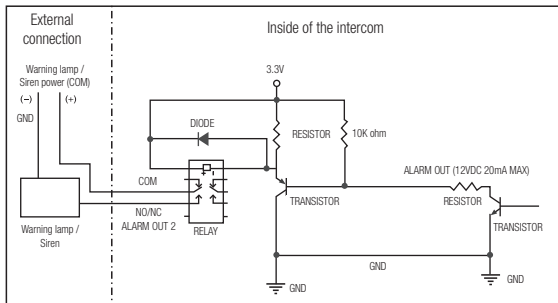

Wiring diagram of warning lamp connected to Alarm out 2

- Warning lamp powered by Power Supply (If intercom and door strike are not connected:)

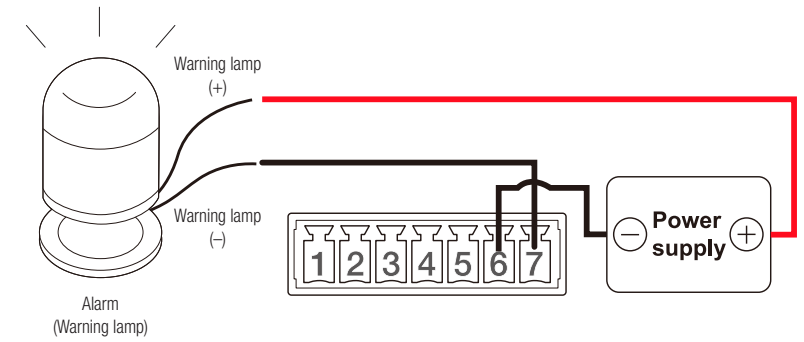

- 1: ALARM IN 1
- 2: ALARM IN 2
- 3: ALARM OUT 1
- 4: GND
- 5: +12V OUT
- 6: COM
- 7: NO/NC (ALARM OUT2)

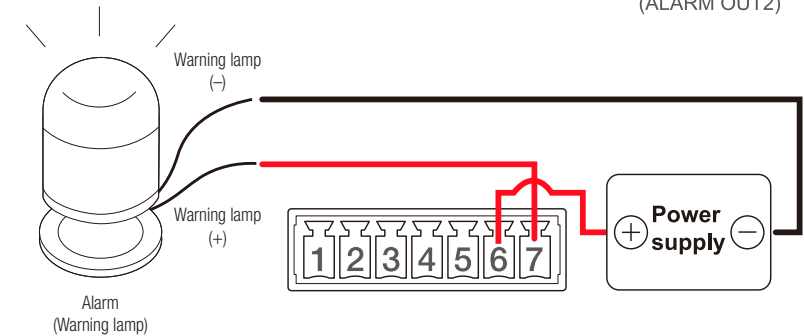

installation & connection

- Warning lamp powered by TID-600R (If intercom and door strike are not connected:)

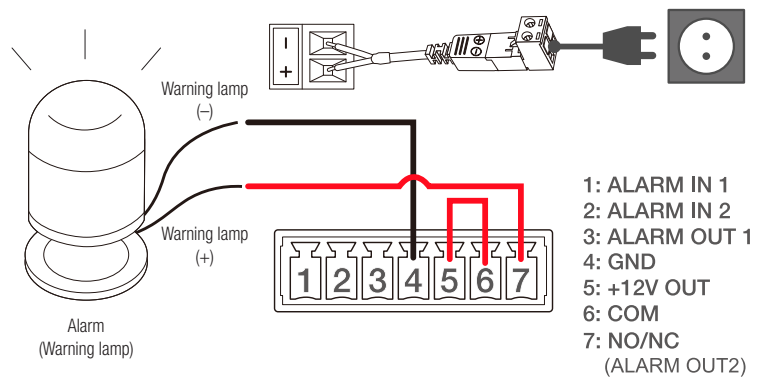
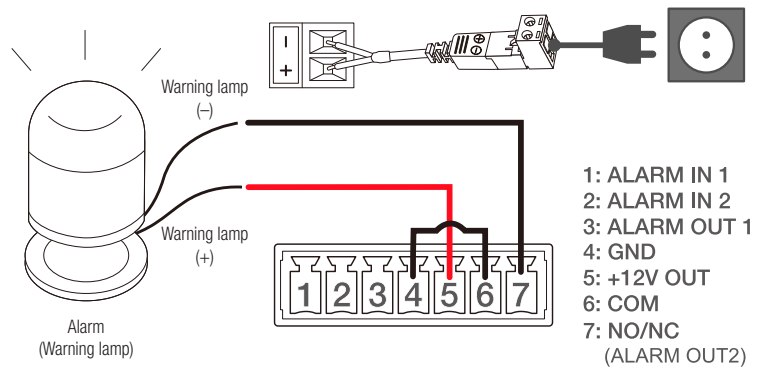

-  You need to connect a warning lamp that uses 12V power to be able to operate only with the power supply from intercom.

network connection and setup

You can set up the network settings according to your network configurations.

CONNECTING THE PRODUCT DIRECTLY TO LOCAL AREA NETWORKING

Connecting to the product from a local PC in the LAN

1. Launch an Internet browser on the local PC.
2. Enter the IP address of the product in the address bar of the browser.

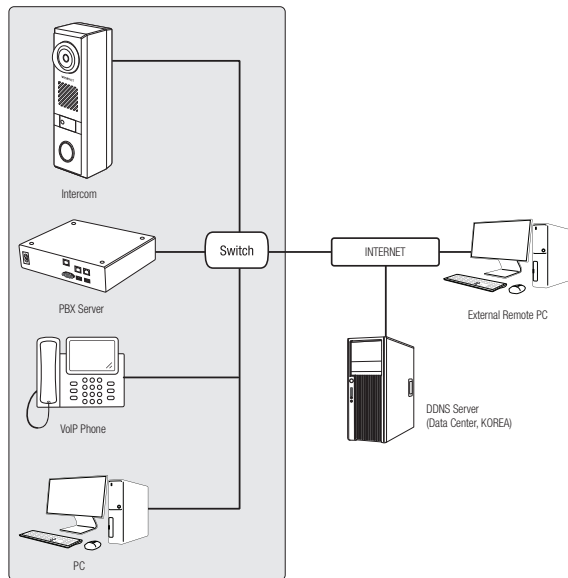

<Local Network>

CONNECTING THE PRODUCT DIRECTLY TO A DHCP BASED DSL/CABLE MODEM

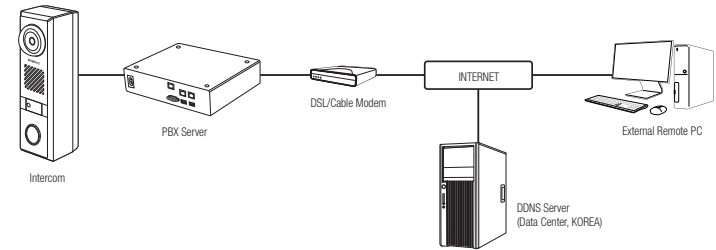

1. Connect the user PC directly with the network product.
2. Run the Device Manager and change the IP address of the product so that you can use the web browser on your desktop to connect to the product.
3. Use the Internet browser to connect to the web viewer.
4. Move to [Setup] page.
5. Move to [Network] – [DDNS] and configure the DDNS settings.
6. Move to [Basic] – [IP & Port], and set the IP type to [DHCP].
7. Connect the product, which was removed from your PC, directly to the modem.
8. Restart the product.

- For information on how to set DDNS, refer to the online help of Web Viewer.
- For information on how to set the IP format, refer to the online help of Web Viewer.

- A remote PC in an external Internet out of the LAN network may not be able to connect to the product installed in the intranet if the port-forwarding is not properly set or a firewall is set. In this case, to resolve the problem, contact your network administrator.
- By factory default, the IP address will be assigned from the DHCP server automatically. If there is no DHCP server available, the IP address will be set to 192.168.1.100. To change the IP address, use the Device Manager. For further details on Device Manager use, refer to "Using Device Manager". (Page 28)
- This product is compatible with SIP-enabled doorphone or PBX devices.
- For a local network that is not connected with external internet, you can set the time manually or by synchronizing with PC. Web viewer setup screen - [Basic] - [Date&Time] - [System time setup]

USING DEVICE MANAGER

- Device manager program can be downloaded from <Technical Support>-<Online Tool> menu at Hanwha Techwin website (<http://www.hanwha-security.com>).
- More instructions of Device Manager can be found at <Help> menu of the main page.

AUTOMATICALLY SEARCHING PRODUCT

If a product is connected to the same network of the PC where device manager is installed, you can find network product by using search function.

- Click <Search> at the main page of device manager.
- Check the product from the list.
 - Check MAC address at the sticker attached to the product.

CONFIGURING IP ADDRESS

If you want to change product network setting, <Login OK> sign must be displayed at <Status>. Click <Authentication> at the main page to log in.

Configuring Static IP

Manually insert and configure IP address & port information.

- Click the product from the list that you want to change the IP setting.
- Click <IP Assign> at the main page of device manager.
- Select <Assign the following IP address>.
 - IP information of the product will be displayed as previously set.
- Fill in IP & Port related categories.

If not using a Broadband Router

For setting <IP Address>, <Subnet Mask>, and <Gateway>, contact your network administrator.

- HTTP Port : Used to access the product using the Internet browser, defaulted to 80.
- RTSP Port: A port that controls real-time streaming. The initial value is 554.

If using a Broadband Router

- IP Address : Enter an address falling in the IP range provided by the Broadband Router.
ex) 192.168.1.2~254, 192.168.0.2~254, 192.168.XXX.2~254
- Subnet Mask : The <Subnet Mask> of the Broadband Router will be the <Subnet Mask> of the product.
- Gateway : The <Local IP Address> of the Broadband Router will be the <Gateway> of the product.

- The settings may differ depending on the connected Broadband Router model. For more information, refer to the user manual of the applicable router.
- For more information about port forwarding of the broadband router, refer to "Port Range Forward (Port Mapping) Setup". (Page 30)

If the Broadband Router has more than one product connected

Configure the IP related settings and the Port related settings distinctly with each other.

ex)

	Category	Product #1	Product #2
IP related settings	IP Address	192.168.1.100	192.168.1.101
	Subnet Mask	255.255.255.0	255.255.255.0
	Gateway	192.168.1.1	192.168.1.1
Port related settings	HTTP Port	8080	8081
	RTSP Port	554	555

- If the <HTTP Port> is set other than 80, you must provide the <Port> number in the address bar of the Internet browser before you can access the product.
ex) http://IP address : HTTP Port
http://192.168.1.100:8080

- Click [Apply] Button.
- If the success message is displayed, click [OK].

Configuring Dynamic IP

Receive IP address from DHCP

- Example of the Dynamic IP environment
 - If a Broadband Router, with products connected, is assigned an IP address by the DHCP server
 - If connecting the product directly to modem using the DHCP protocols
 - If IPs are assigned by the internal DHCP server via the LAN

1. Click the product from the list that you want to change the IP setting.
2. Click **<IP Assign>** at the main page of device manager.
3. Select **<Obtain an IP address automatically (DHCP)>**.
4. Click **[Apply]** button.
5. If the success message is displayed, click **[OK]**.

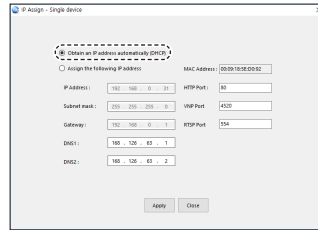

AUTOMATICALLY CONFIGURING IP

1. Click the product from the list that you want to automatically configure the IP.
2. Click **<+ >** at the main page of device manager.
 - Equipment Setting menu appears.
3. At the menu, click **<Auto IP Configure>**.
4. Click **[Close]** button.

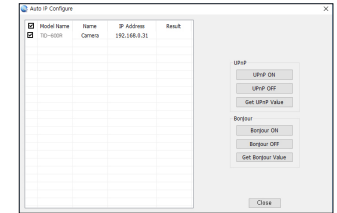

MANUALLY REGISTERING PRODUCT

If the product cannot be found using search function, the product can be registered remotely by manually inserting IP information, if the product is connected to external network.

1. Click **<Add Devices>** - **<Manually Add Device>** at the main page of device manager.
2. Insert the range of IP address that you search.
3. Select the **<Model Name>** of the product that you register, and insert HTTP port, ID, and password.
4. Click **[Register]** button.
5. Check if product is registered.
 - Check MAC address at the sticker attached to the product.

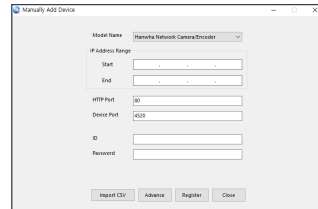

PORT RANGE FORWARD (PORT MAPPING) SETUP

If you have installed a Broadband Router with a product connected, you must set the port range forwarding on the Broadband Router so that a remote PC can access the product in it.

Manual Port Range Forwarding

1. From the Setup menu of the Broadband Router, select **<Applications & Gaming>** - **<Port Range Forward>**. For setting the port range forward for a third-party Broadband Router, refer to the user guide of that Broadband Router.
2. Select **<TCP>** and **<UDP Port>** for each connected product to the Broadband Router.
The number of each port to be configured to the IP router should be set according to the port number designated in **<Setup>** - **<Basic>** - **<IP & Port>** on the product web viewer.
3. When done, click **[Save Settings]**.
Your settings will be saved.

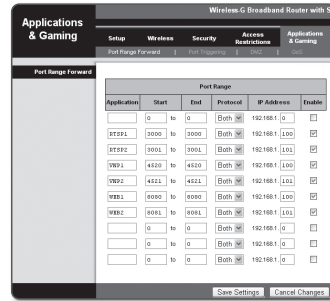

- Port forwarding setting is an example of setting CISCO IP router.
- The settings may differ depending on the connected Broadband Router model. For more information, refer to the user manual of the applicable router.

Setting up Port Range Forward for several network products

- You can set a rule of Port Forwarding on the Broadband Router device through its configuration web page.
- A user can change each port using the product setting screen.

When Product1 and Product2 are connected to a router :

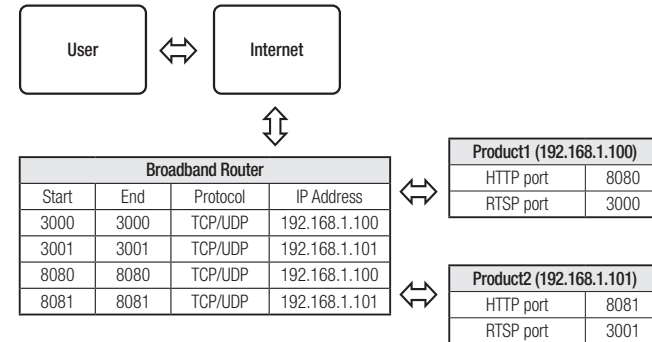

- Port forwarding can be done without additional router setup if the router supports the UPnP (Universal Plug and Play) function. After connecting the network product, select the checkbox from the menu **<Quick connect>** in **<Wisenet DDNS>** in **"Settings -> Network -> DDNS"**.

CONNECTING TO THE PRODUCT FROM A SHARED LOCAL PC

1. Run device manager.
It will scan for connected products and display them as a list.
2. Double-click a product to access.
The Internet browser starts and connects to the product.



- Access to the product can also be gained by typing the product's IP address in the address bar of the Internet browser.

CONNECTING TO THE PRODUCT FROM A REMOTE PC VIA THE INTERNET

On a remote computer that is not in the Broadband Router's network cluster is not allowed, users can access products within a Broadband Router's network by using the product's DDNS URL.

1. Before you can access a product in the Broadband Router network, you should have set the port range forward for the Broadband Router.
2. From the remote PC, launch the Internet browser and type the DDNS URL address of the product, or the IP address of the Broadband Router in the address bar.
ex) <http://ddns.hanwha-security.com/ID>



- To use Wisenet DDNS, sign up at the Wisenet DDNS homepage (<http://ddns.hanwha-security.com>) and register the product at **[My DDNS]>[Register Product]**.

CONNECTING TO THE PRODUCT

Normally, you would

1. Launch the Internet browser.
2. Type the IP address of the product in the address bar.
 - ex) • IP address (IPv4) : 192.168.1.100 → http://192.168.1.100
 - the Login dialog should appear.
 - IP address (IPv6) : 2001:230:abcd:ffff:0000:0000:ffff:1111 → http://[2001:230:abcd:ffff:0000:0000:ffff:1111]
 - the Login dialog should appear.

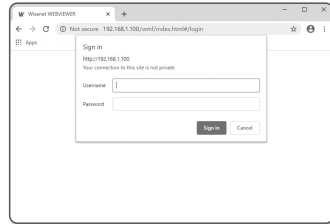

If the HTTP port is other than 80

1. Launch the Internet browser.
2. Type the IP address and HTTP port number of the product in the address bar.
 - ex) IP address : 192.168.1.100:HTTP Port number(8080)
 - http://192.168.1.100:8080 - the Login dialog should appear.

Using URL

1. Launch the Internet browser.
2. Type the DDNS URL of the product in the address bar.
 - ex) URL address : http://ddns.hanwha-security.com/ID
 - the Login dialog should appear.



- Network connection is disabled in the LAN only environment.

Connecting via UPnP

1. Run the client or operating system in support of the UPnP protocol.
2. Click the product name for search.
 - In the Windows operating system, click the product name searched from the network menu.
 - The login window is displayed.

Connecting via Bonjour

1. Run the client or operating system in support of the Bonjour protocol.
2. Click the product name for search.
 - In the Mac operating system, click the product name searched from the Bonjour tab of Safari.
 - The login window is displayed.

To check the DDNS address

If the product is connected directly to the DHCP cable modem, DSL modem, the IP address of your network will be changed each time you try to connect to the ISP (Internet Service Provider) server. If this is the case, you will not be informed of the IP address changed by DDNS.

Once you register a dynamic IP-based device with the DDNS server, you can easily check the changed IP when you try to access the device.

To register your device to the <DDNS> server, visit <http://ddns.hanwha-security.com> and register your device first, and then set the Web Viewer's <Network> - <DDNS> to <Wisenet DDNS>, as well as providing <Product ID> that had been used for DDNS registration.

PASSWORD SETTING

When you access the intercom for the first time, you must register the login password.



- For a new password with 8 to 9 digits, you must use at least 3 of the following: uppercase/lowercase letters, numbers and special characters. For a password with 10 to 15 digits, you must use at least 2 types of those mentioned.
 - Special characters that are allowed: ~!@#\$%^&*()_+=|{}[]?/
- For higher security, you are not recommended to repeat the same characters or consecutive keyboard inputs for your passwords.
- If you lost your password, you can press the **[RESET]** button to initialize the product. So, don't lose your password by using a memo pad or memorizing it.

Administrator password change

New password

Confirm new password

• If the password is 8 to 9 characters long, then it must include a combination of at least 3 of the following character types: alphabet letters with uppercase or lowercase, numbers, and special characters.

• If the password is longer than 10 characters, then it must include a combination of at least 2 of the following character types: alphabet letters with uppercase or lowercase, numbers, and special characters.

- User name may not be used as password.
- The following special characters can be used: ~!@#\$%^&*()_+=|{}[]?/;
- You may not use more than 4 consecutive characters: (1234, abc, etc.)
- You may not use the same character 4 or more times consecutively: (aaabbb, 1111, aaa, etc.)

Apply

LOGIN

Whenever you access the intercom, the login window appears. Enter the User ID and password to access the intercom.

- Enter **“admin”** in the **<User name>** input box. The administrator ID, **“admin”**, is fixed and can not be changed.
- Enter the password in the **<Password>** input field.
- Click **[Sign in]**.
If you have logged in successfully, you will the Live Viewer screen.



- When you access the intercom web viewer, pay special attention to the security by checking whether the image data is encrypted.



- You will experience the best video quality if the screen size is 100%. Reducing the ratio may cut the image on the borders.

Sign in

http://192.168.1.100

Your connection to this site is not private

Username

Password

Sign in Cancel

INTERCOM WEB VIEWER SETUP

- Click the **[Setup (⚙)]** icon.
- The Settings window appears.
- You can configure settings for the intercom's basic information, video, audio, network, event, analysis, and system over the network.
- Click **<Help (?)>** to view detailed descriptions of each function.

TROUBLESHOOTING

PROBLEM	SOLUTION
When an Windows 10 user accesses the web viewer through Chrome or Firefox, the sound volume of microphone changes periodically.	<ul style="list-style-type: none"> This is what happens when microphone driver has been set to Realtek driver. Install the High Definition Audio device (Windows Default Driver) or the third party driver as the microphone driver.
What are the specifications for WAVE files necessary to play audio at the time of an event?	<ul style="list-style-type: none"> Sampling rate of 48,000 KHz or less is recommended. For bits per sample (bps), up to 8/16 bit is recommended. Only PCM encoding format is supported.
No video is displayed when accessing the plug-in free webviewer on Safari via HTTPS.	<ul style="list-style-type: none"> On the authentication popup window prompted when initially accessing https, click "View Authentication Certificate" and select the "Always trust when connecting to the designated webviewer IP" check box. If the webviewer continues failing to display a video after you select "Next" on the message window below, press the command key + Q to exit the Safari browser, access again and follow the procedures stated above.
I can't access the intercom from a web browser.	<ul style="list-style-type: none"> Check to make sure that the intercom's Network settings are appropriate. Check to make sure that all network cables have been connected properly. If connected using DHCP, verify that the intercom is able to acquire dynamic IP addresses without any problem. If the intercom is connected to a Broadband Router, verify that port forwarding is properly configured.
Viewer got disconnected during monitoring.	<ul style="list-style-type: none"> Connected Viewers become disconnected upon any change to intercom or network configurations. Check all network connections.
The intercom connected to the network is not detected in the Device Manager program.	<ul style="list-style-type: none"> Turn off the firewall settings on your PC and then search the intercom again.
Images overlap.	<ul style="list-style-type: none"> Check whether two or more intercoms are set to a single multicast address instead of different addresses. If a single address is used for multiple intercoms, the images may overlap.

PROBLEM	SOLUTION
No image appears.	<ul style="list-style-type: none"> If the transmission method is set to multicast, check whether there is a router that supports multicast in the LAN the intercom is connected to.
Voice is not recorded even though audio input settings are configured.	<ul style="list-style-type: none"> You must enable the <Audio In> check box in <Basic> - <Video Profile>.
<Motion detection> of <Analytics> is set to <Enable>, but no notification e-mail reaches me even when an analysis event had occurred.	<ul style="list-style-type: none"> Verify the settings in the following sequence: <ol style="list-style-type: none"> Check <Data & Time> settings. The <Motion detection> should be set to <Enable>. Check if the <E-mail> option of <Event setup> menu is checked to use.
No signal is found at the Alarm Output port even when an intelligent video analysis event is generated.	<ul style="list-style-type: none"> Check alarm output port settings.
Cannot record into the Micro SD card.	<ul style="list-style-type: none"> Check if the Micro SD card is defective. When replacing the Micro SD card, it must be done while the power is disconnected from the product.
Micro SD card is inserted but the intercom does not operate properly.	<ul style="list-style-type: none"> Check if the Micro SD card is inserted in the proper direction. Operation of Micro SD card that is formatted by other devices is not guaranteed with this intercom unit. Format the Micro SD card again in <Setup> → <Event> → <Storage> menu.
Cannot record in the NAS.	<ul style="list-style-type: none"> Confirm that the information registered in the NAS is correct.
It reports that NAS setting has failed.	<ul style="list-style-type: none"> Confirm that the IP address of the NAS is valid. Confirm that the ID/password of the NAS is valid. Confirm that you can access the folder designated as the default folder using the ID of the NAS. Confirm that the NAS SMB/CIFS items are unchecked. Confirm that the NAS IP address and the intercom IP address are in the same format. <p>ex) The NAS & intercom subnet mask initial value is 255.255.255.0.</p> <p>If the IP address is 192.168.20.32 then the NAS IP address should be in the range of 192.168.20.1~192.168.20.255.</p> Check whether you tried to access as another user without formatting the default folder saved or used. Confirm that you used recommended NAS equipment.



Any changes or modifications in construction of this device which are not expressly approved by the party responsible for compliance could void the user's authority to operate the equipment.

This device complies with part 15 of the FCC Rules. Operation is subject to the following two conditions: (1) This device may not cause harmful interference, and (2) this device must accept any interference received, including interference that may cause undesired operation.

This equipment has been tested and found to comply with the limits for a Class A digital device, pursuant to part 15 of the FCC Rules. These limits are designed to provide reasonable protection against harmful interference when the equipment is operated in a commercial environment. This equipment generates, uses, and can radiate radio frequency energy and, if not installed and used in accordance with the instruction manual, may cause harmful interference to radio communications. Operation of this equipment in a residential area is likely to cause harmful interference in which case the user will be required to correct the interference at his own expense.



Hanwha Techwin cares for the environment at all product manufacturing stages, and is taking measures to provide customers with more environmentally friendly products.

The Eco mark represents Hanwha Techwin's devotion to creating environmentally friendly products, and indicates that the product satisfies the EU RoHS Directive.



Correct Disposal of This Product (Waste Electrical & Electronic Equipment)

(Applicable in the European Union and other European countries with separate collection systems)

This marking on the product, accessories or literature indicates that the product and its electronic accessories (e.g. charger, headset, USB cable) should not be disposed of with other household waste at the end of their working life. To prevent possible harm to the environment or human health from uncontrolled waste disposal, please separate these items from other types of waste and recycle them responsibly to promote the sustainable reuse of material resources.

Household users should contact either the retailer where they purchased this product, or their local government office, for details of where and how they can take these items for environmentally safe recycling.

Business users should contact their supplier and check the terms and conditions of the purchase contract. This product and its electronic accessories should not be mixed with other commercial wastes for disposal.



Correct disposal of batteries in this product

(Applicable in the European Union and other European countries with separate battery return systems.)

This marking on the battery, manual or packaging indicates that the batteries in this product should not be disposed of with other household waste at the end of their working life. Where marked, the chemical symbols Hg, Cd or Pb indicate that the battery contains mercury, cadmium or lead above the reference levels in EC Directive 2006/66. If batteries are not properly disposed of, these substances can cause harm to human health or the environment.

To protect natural resources and to promote material reuse, please separate batteries from other types of waste and recycle them through your local, free battery return system.

